

[CONTRIBUTION FROM THE DEPARTMENT OF CHEMISTRY AND RESEARCH LABORATORY OF ELECTRONICS, MASSACHUSETTS INSTITUTE OF TECHNOLOGY, CAMBRIDGE, MASSACHUSETTS]

## A Kinetic Study of Glutamic-Aspartic Transaminase<sup>1</sup>

BY GORDON G. HAMMES AND PAOLO FASELLA

RECEIVED JULY 18, 1962

Kinetic studies of glutamic-aspartic transaminase have been made at high enzyme concentrations ( $>10^{-6}$  M) using the temperature jump method. The observed relaxation times ranged from less than 50  $\mu$ sec. to about 20 msec. The minimal mechanism consistent with spectral and kinetic data is



Here  $E_L$  is the aldehydic form of the enzyme,  $E_M$  is the aminic form, Gm, Kg, Oa, and As are the substrates glutamate, ketoglutarate, oxalacetate, and aspartate, respectively, and the X's and Y's are enzyme-substrate intermediates. Individual rate constants or lower bounds thereof were obtained for all of the steps; in addition approximate spectra were found for the intermediates which are consistent with their being Schiff bases. The binding constants for Schiff base formation are quite high— $10^8$  to  $10^6$  M<sup>-1</sup> depending on the specific substrate. The measured bimolecular rate constants are all about  $10^7$  M<sup>-1</sup> sec.<sup>-1</sup>, and the rate constants for the interconversion of intermediates are between 10 and  $10^2$  sec.<sup>-1</sup>. These results are also in accord with stopped-flow and equilibrium dialysis experiments.

### Introduction

The mechanism of enzymatic transamination has been the subject of many investigations,<sup>2</sup> but very little direct information has been obtained concerning the number and nature of the enzyme-substrate intermediates involved. This is due primarily to the fact that most kinetic studies have been carried out at very low enzyme concentrations (as is true with most enzyme systems) in order to make the time scale of the reaction experimentally accessible. Of course, at low enzyme concentrations direct observation of the intermediates is virtually impossible. On the other hand, spectral observations at high enzyme concentrations cannot be interpreted reliably because of the spectral overlap of the intermediates and native enzyme. The recent development of the temperature jump technique<sup>3-5</sup> for studying fast reactions in solution offers the attractive possibility of carrying out kinetic studies at high concentrations of enzyme, thus permitting direct observation of the intermediates. The principle of the temperature jump method is to perturb an equilibrium reaction mixture by rapidly raising the temperature and then to observe the rate with which the system attains its new equilibrium state. This rate is characterized by a spectrum of relaxation times which are functions of the rate constants and equilibrium concentrations.<sup>6</sup> Determination of the relaxation spectrum, therefore, permits the evaluation of kinetic parameters. The analysis is simplified by the fact that all rate processes near equilibrium are first order. The presence of a coenzyme in most transaminases endows this type of enzyme with spectral properties which are very convenient for following the reaction progress. Glutamic-aspartic transaminase was selected for study since it can now be obtained pure in relatively large quantities.<sup>7,8</sup>

Purified glutamic-aspartic transaminase has been shown to react with its substrates according to the general scheme<sup>9,10</sup>

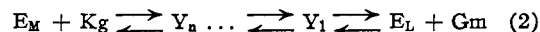

Here  $E_L$  is the aldehydic form of the enzyme,  $E_M$  is the aminic form,  $X_n$  and  $Y_n$  designate enzyme-substrate intermediates, As is aspartate, Oa is oxalacetate, Gm is glutamate, and Kg is ketoglutarate. The number and nature of the intermediates  $X_n$  and  $Y_n$ , however, could not be determined. Steady state kinetic studies are in agreement with the above mechanism,<sup>11,12</sup> but the resultant Michaelis constants and maximum velocities are in general complicated functions of the rate constants and thus permit no conclusions to be drawn concerning the intermediate steps. Attempts to study the reaction of the aldehydic form of the enzyme with glutamate and aspartate by use of the stopped flow method<sup>13</sup> showed that the half time of the reaction (as measured by a decrease in absorbance at 360  $\mu$ ) is about 5 msec., which is very close to the resolution time of this method. Furthermore, ignorance of the number and absorption spectra of the various enzyme-substrate complexes makes the interpretation of such experiments in terms of a detailed mechanism extremely difficult.

In the work presented here, the kinetics of each half of the reaction was studied separately by the temperature jump method. Three relaxation times were observed for each of the two systems ranging from less than 50  $\mu$ sec. to about 20 msec. The concentration dependence of the relaxation times indicates that each half of the reaction proceeds through the formation of at least two intermediates ( $X_1$ ,  $X_2$ , and  $Y_1$ ,  $Y_2$ ). Furthermore ten of the twelve rate constants and all of the individual equilibrium constants could be calculated. Coupling these results with equilibrium measurements of the

(1) Supported in part by U. S. Army Signal Corps, Air Force, Office of Scientific Research, and Office of Naval Research and in part by the National Institutes of Health.

(2) (a) E. E. Snell, *Vitamins and Hormones*, **16**, 77 (1958); (b) A. E. Braunstein, "The Enzymes," Vol. II, Academic Press, New York, N. Y., 1960, p. 113.

(3) G. Czerlinski and M. Elgen, *Z. Elektrochem.*, **63**, 652 (1959).

(4) H. Diebler, Dissertation, Universität Göttingen, 1960.

(5) L. de Maeyer, *Z. Elektrochem.*, **64**, 65 (1960).

(6) M. Elgen, *ibid.*, **64**, 115 (1960).

(7) H. Lis, *Biochim. et Biophys. Acta*, **28**, 191 (1958).

(8) W. T. Jenkins, D. A. Yphantis and I. W. Sizer, *J. Biol. Chem.*, **234**, 51 (1959).

(9) W. T. Jenkins and I. W. Sizer, *ibid.*, **235**, 620 (1960).

(10) H. Lis, P. Fasella, C. Turano and P. Vecchini, *Biochim. et Biophys. Acta*, **45**, 529 (1960).

(11) C. Turano, P. Fasella and A. Giartosio, *ibid.*, **58**, 255 (1962).

(12) S. F. Velick and J. Varra, *J. Biol. Chem.*, **237**, 2109 (1962).

(13) H. Gutfreund, *Nature*, **192**, 820 (1961).

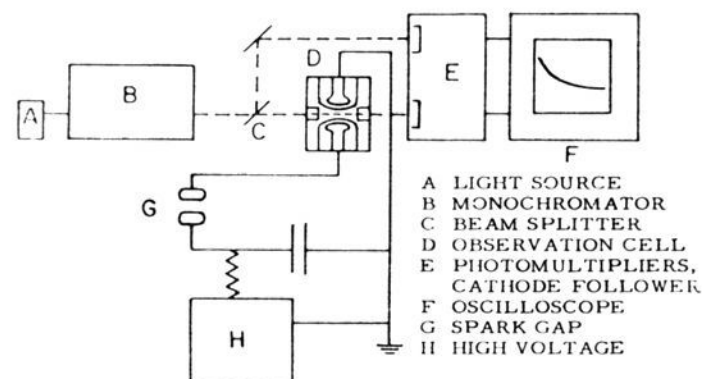

Fig. 1.—Block diagram of the temperature jump apparatus.

absorption spectra of various reaction mixtures permitted some spectral characteristics of the enzyme-substrate complexes to be evaluated. These results allow tentative conclusions to be made concerning the detailed mechanism of the transamination. In addition, stopped flow and equilibrium dialysis experiments are in accord with these conclusions.

### Experimental

The temperature jump apparatus used was a modification of that described by Czerlinski and Eigen.<sup>3</sup> A schematic sketch of the system is shown in Fig. 1. In actual operation, the 0.1  $\mu$ fd. condenser (Plastic Capacitors, Inc.) is charged to 30,000 volt, and then discharged through a suitably adjusted air gap. The observation cell, constructed from Plexiglas, is connected in parallel with the condenser via two brass platinized electrodes, and the discharge heats the volume of solution ( $\sim 1.2$  cc.) between the two electrodes. The temperature jump is about 8°. The entire discharge circuit is constructed concentrically and lined with mu metal to eliminate the effect of the magnetic field on the photomultipliers; the observation cell is surrounded by a thermostatted jacket. The relaxation time (reciprocal first order rate constant) of the heating period is  $RC/2^3$  where  $R$  is the resistance of the cell and  $C$  is 0.1  $\mu$ fd. For the apparatus being described here,  $RC/2$  is about 5  $\mu$ sec. so that chemical events occurring in times longer than 5–10  $\mu$ sec. can be observed. Monochromatic light is obtained from a 100-watt tungsten lamp (Osram, West Germany) coupled with a Bausch and Lomb monochromator. The light is split into two beams by a half surfaced mirror; one beam passes through the cell to a photomultiplier (RCA 1P28), the other through air to a second photomultiplier. The path length through the solution is 1 cm. The intensities of the parallel beams of light are adjusted through use of diaphragms so that initially the photomultiplier outputs are equal; deviations from this null point produced by the temperature jump are observed on a Tektronix 545A oscilloscope equipped with a differential preamplifier. The oscilloscope is triggered with the voltage induced in a small coil near the spark gap by the discharge. Absorption changes as small as 0.1% can be measured in this manner. The relaxation effects were photographed with a Polaroid Land Camera.

The purified enzyme was prepared as previously described<sup>7</sup> and the amino and ketoacids were obtained from Calbiochem. All other chemicals were standard analytical grade reagents.

The general procedure was to mix the pyridoxal (aldehydic) form of the enzyme with varying proportions of glutamate or aspartate. All solutions were 0.16  $M$  in phosphate buffer and were adjusted to pH  $8.0 \pm 0.1$ . Since the temperature jump cell requires about 25 ml. of solution, a substantial amount of enzyme is needed for each experiment. The equilibrium mixtures containing the various forms of the enzymes and substrates were thermostatted at 17° in the temperature jump cell and temperature jumps of 8° were applied to the solution as previously described. About four minutes were allowed to elapse between pulses in order to reestablish thermal equilibrium in the system. Each relaxation effect was photographed several times and the relaxation times were evaluated from the slopes of plots of the logarithm of the amplitude versus time. An actual oscilloscope trace of a system with two observable relaxation is shown in Fig. 2.

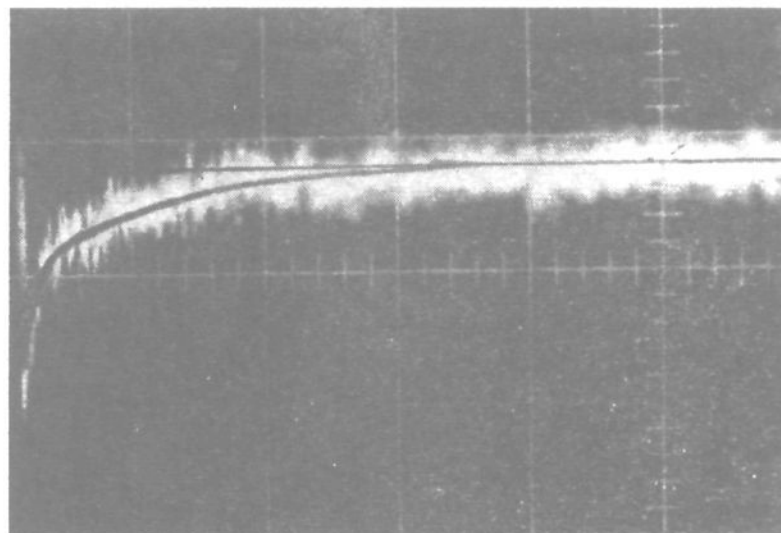

Fig. 2.—Relaxation effect in a transaminase system beginning with glutamate and pyridoxal enzyme:  $(S_0) = 2 \times 10^{-4} M$  and  $(E_0) = 5 \times 10^{-6} M$ , pH 7.9,  $\lambda = 430 m\mu$ . The abscissa scale is 10 msec. per major division and the vertical scale is in arbitrary units of absorbency. The relaxation effect corresponds to a decrease in absorbance with time.

The wave length of the monochromatic light used was 430  $m\mu$ . This wave length was found to give optimal effects over the spectral range of 350 to 510  $m\mu$ . There are several possible reasons for the fact that the optimal effect is observed at this wave length. The sensitivity of the apparatus is not good at lower wave lengths ( $< 400 m\mu$ ) because of the sharp decrease in lamp intensity so that the experiments could not be carried out at 360  $m\mu$ , the absorption maximum of  $E_L$ , or at 330  $m\mu$ , the absorption maximum of  $E_M$ . One possibility is that the spectral tail of the 360 peak is being observed; however, it is more probable that the presence of very small amounts of either the protonated form of the  $E_L$  enzyme, ( $HE_L$ ), or its complex with the keto acid (both have absorption maxima at 430  $m\mu$ ) is serving as an indicator. In keeping with this hypothesis the reaction of  $HE_L$  and keto acid to form a complex and the protonation of  $E_L$  have been shown to occur faster (under similar conditions) than any of the observed relaxation times through independent experiments.<sup>14</sup> The absorption spectrum and catalytic activity of the enzyme were determined with a Beckman DU Spectrophotometer before and after temperature jump experiments to check for possible enzyme denaturation. Approximately twenty high voltage pulses could be applied without any sign of denaturation.

Stopped flow experiments were carried out in an apparatus constructed from Plexiglas and glass syringes. A four jet mixer was used and the path length of the observation chamber was 1 cm. The detection system for measurement of absorbency changes in the sample was similar to that employed in the temperature jump. The resolution time of the apparatus was 5–10 msec. and the sensitivity was such that 1% changes in absorption could be detected. A detailed description of the apparatus is available elsewhere.<sup>15</sup> Four reactions were studied at a wave length of 390  $m\mu$ :  $E_L + Gm$ ,  $E_L + As$ ,  $E_M + Oa$ , and  $E_M + Kg$ . In all experiments, either  $E_L$  or  $E_M$  was present at a concentration of  $2 \times 10^{-5} M$ , while the substrate concentrations were made as large as possible—the limit being set by the resolution time of the apparatus.

The equilibrium dialysis experiments were carried out with 1.3-cm. Visking tubing which was first soaked 3 min. in  $5 \times 10^{-3} N$  NaOH and washed with distilled water according to the method of Scatchard and Pigliacampi.<sup>16</sup> Approximately 2 ml. of 0.16  $M$  phosphate buffer, pH 8, was placed in the sack and dialyzed against 5 ml. of enzyme and substrate solution in the same buffer. Four initial combinations of enzyme and substrate were investigated.  $E_L + Gm$ ,  $E_L + As$ ,  $E_M + Kg$ , and  $E_M + Oa$ . Blank runs of the enzyme and substrate alone also were made. In order to prevent enzyme denaturation, the experiments had to be carried out at 4° and the dialysis time had to be minimized.

(14) G. G. Hammes and P. Fasella, to be published.

(15) G. Becker, B.S. Thesis, M.I.T., 1962.

(16) G. Scatchard and J. Pigliacampi, *J. Am. Chem. Soc.*, **84**, 127 (1962).

TABLE I  
 REACTION BETWEEN TRANSAMINASE AND ASPARTATE-OXALACETATE<sup>a</sup>

Concentrations, <i>M</i>						Relaxation times, msec.					
<i>S</i> <sub>0</sub>	<i>E</i> <sub>0</sub>	<i>E</i> <sub>L</sub>	<i>X</i> <sub>1</sub>	<i>X</i> <sub>2</sub>	<i>E</i> <sub>M</sub> (= <i>Oa</i> )	I		II		III	
						Exp.	Calcd.	Exp.	Calcd.	Exp.	Calcd.
1.90 × 10 <sup>-4</sup>	1.90 × 10 <sup>-5</sup>	6.80 × 10 <sup>-6</sup>	2.10 × 10 <sup>-6</sup>	6.50 × 10 <sup>-6</sup>	3.60 × 10 <sup>-6</sup>	<0.100	...	..	..	..	..
1.60 × 10 <sup>-4</sup>	2.60 × 10 <sup>-5</sup>	1.06 × 10 <sup>-5</sup>	2.85 × 10 <sup>-6</sup>	8.80 × 10 <sup>-6</sup>	4.20 × 10 <sup>-6</sup>	...	...	..	..	1.3	1.39
8.00 × 10 <sup>-5</sup>	2.65 × 10 <sup>-5</sup>	1.55 × 10 <sup>-5</sup>	1.86 × 10 <sup>-6</sup>	5.74 × 10 <sup>-6</sup>	3.40 × 10 <sup>-6</sup>	...	...	..	..	1.8	1.62
3.73 × 10 <sup>-4</sup>	3.68 × 10 <sup>-5</sup>	8.80 × 10 <sup>-6</sup>	5.50 × 10 <sup>-6</sup>	1.67 × 10 <sup>-6</sup>	5.80 × 10 <sup>-6</sup>	...	...	18	18.7	..	..
7.18 × 10 <sup>-4</sup>	3.40 × 10 <sup>-5</sup>	4.65 × 10 <sup>-6</sup>	5.70 × 10 <sup>-6</sup>	1.77 × 10 <sup>-6</sup>	5.95 × 10 <sup>-6</sup>	...	...	75	15.8	1.07	1.02

<sup>a</sup> pH 8.0, 25°.

 TABLE II  
 REACTION BETWEEN TRANSAMINASE AND GLUTAMATE-KETOGLUTARATE<sup>a</sup>

Concentrations, <i>M</i>						Relaxation times, msec.					
<i>S</i> <sub>0</sub>	<i>E</i> <sub>0</sub>	<i>E</i> <sub>L</sub>	<i>X</i> <sub>1</sub>	<i>X</i> <sub>2</sub>	<i>E</i> <sub>M</sub> (= <i>Kg</i> )	I		II		III	
						Exp.	Calcd.	Exp.	Calcd.	Exp.	Calcd.
2.60 × 10 <sup>-5</sup>	2.60 × 10 <sup>-5</sup>	1.43 × 10 <sup>-5</sup>	2.52 × 10 <sup>-6</sup>	5.04 × 10 <sup>-6</sup>	4.10 × 10 <sup>-6</sup>	0.300	0.270	..	..	4.1	3.96
7.80 × 10 <sup>-5</sup>	2.60 × 10 <sup>-5</sup>	6.90 × 10 <sup>-6</sup>	4.53 × 10 <sup>-6</sup>	9.07 × 10 <sup>-6</sup>	5.50 × 10 <sup>-6</sup>	...	...	..	..	3.1	3.22
2.00 × 10 <sup>-4</sup>	5.30 × 10 <sup>-6</sup>	6.70 × 10 <sup>-6</sup>	1.24 × 10 <sup>-5</sup>	2.48 × 10 <sup>-6</sup>	9.10 × 10 <sup>-6</sup>	0.110	0.122	16	14.5	2.1	2.19
4.00 × 10 <sup>-4</sup>	5.30 × 10 <sup>-6</sup>	3.30 × 10 <sup>-6</sup>	1.34 × 10 <sup>-5</sup>	2.68 × 10 <sup>-6</sup>	9.50 × 10 <sup>-6</sup>	...	...	13	13.3	1.5	2.10

<sup>a</sup> pH 8.0, 25°.

The minimum time for equilibration without denaturation was found to be about 6 hours for experiments beginning with the *E*<sub>L</sub> enzyme and 3 hours for those beginning with the *E*<sub>M</sub> enzyme. The solutions were slowly but continuously stirred during the dialysis. At the end of the dialysis the contents of the dialysis bag were analyzed quantitatively for keto acids with 2,4-dinitrophenylhydrazine<sup>17</sup> and for amino acids with ninhydrin according to Moore and Stein.<sup>18</sup>

### Results

For each of the reactions (1 and 2), three relaxation times were observed. No relaxation effects were found without substrate being present. In the case of the glutamate-enzyme system, all three relaxation times could be measured, while in the case of the aspartate-enzyme system only two of the relaxation times could be measured, although an upper bound could be obtained for the third. The results of these experiments are reported in Tables I and II together with the total enzyme (*E*<sub>0</sub>) and substrate (*S*<sub>0</sub>) concentrations employed. The relaxation times are averages obtained from several photographs and probably are only precise to ± 15% due to the small absolute magnitude of the effects. In reaction mixtures containing lower total concentrations of enzyme and substrate, the relaxation effects become too small for quantitative evaluation. At higher substrate concentrations, substrate inhibition occurred. This latter phenomenon will be discussed more fully a little later.

Each of the four reactions studied in the stopped flow requires some special comment. For *E*<sub>L</sub> + *Gm*, the concentration of *Gm* was much greater than that of *E*<sub>L</sub> in an attempt to make the reaction pseudo first order; unfortunately the observable change in absorption was quite small at times greater than 5–10 msec. However, an approximate pseudo first order rate constant was determined by plotting the logarithm of the signal amplitude versus time. In the case of *E*<sub>L</sub> + *As*, no reliable first order constant could be obtained since the reaction became too fast when the concentration of *As* was high enough to cause a measurable absorption change. A lower bound of this rate constant can be calculated by making the conservative esti-

mate that the reciprocal rate constant is less than 10 msec. if the reaction is too fast to measure. The reaction of *E*<sub>M</sub> + *Kg* was found to be initially second order when *E*<sub>M</sub> = *Kg* = 2 × 10<sup>-5</sup> *M*; at higher concentrations the reaction was too fast to measure. For *E*<sub>M</sub> + *Oa*, a lower bound for the second order rate constant could be obtained by assuming *t*<sub>1/2</sub> < 10 msec. when the reaction was too fast to study with *E*<sub>M</sub> = *Oa* = 2 × 10<sup>-5</sup> *M*. The results obtained are given in Table III.

Not too much significance can be attached to the stopped flow measurements since the rates involved are really too fast for this method. The measured rate constants are precise only to ± 40%, while the lower bounds could easily be a factor of two larger because of the conservative estimate of the apparatus resolution time.

 TABLE III  
 STOPPED FLOW RESULTS

Concentration, <i>M</i>		<i>k</i> , <i>M</i> <sup>-1</sup> sec. <sup>-1</sup>	
Enzyme	Substrate	Stopped flow	Temp. jump
<i>E</i> <sub>L</sub> = 2 × 10 <sup>-5</sup>	<i>Gm</i> = 2 × 10 <sup>-4</sup>	1.2 × 10 <sup>6</sup>	7.2 × 10 <sup>6</sup>
<i>E</i> <sub>L</sub> = 2 × 10 <sup>-5</sup>	<i>As</i> = 3 × 10 <sup>-3</sup>	> 4.5 × 10 <sup>6</sup>	1.5 × 10 <sup>6</sup>
<i>E</i> <sub>M</sub> = 2 × 10 <sup>-4</sup>	<i>Kg</i> = 2 × 10 <sup>-5</sup>	4.5 × 10 <sup>6</sup>	9.0 × 10 <sup>6</sup>
<i>E</i> <sub>M</sub> = 2 × 10 <sup>-4</sup>	<i>Oa</i> = 2 × 10 <sup>-5</sup>	> 5 × 10 <sup>6</sup>	1.3 × 10 <sup>7</sup>

The equilibrium dialysis experiments were intended to yield some information on the magnitude of the enzyme-substrate binding constants. The results of four experiments are given in Table IV. The concentrations of amino and keto acids found are often close to the limit of the analytical methods employed so that experimental errors of ± 5–10% are expected.

### Discussion

Since no relaxation effects were observed in the absence of substrates, it seems quite certain that the time constants reported are characteristic of the enzymatic reaction. Because three relaxation times are observed, a minimal mechanism requires three steps in each half reaction; the simplest possibility is

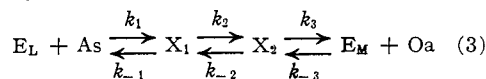

(17) H. J. Koepsell and E. S. Sharp, *Arch. Biochem. Biophys.*, **38**, 443 (1952).

(18) S. Moore and W. H. Stein, *J. Biol. Chem.*, **211**, 909 (1954).

TABLE IV  
 EQUILIBRIUM DIALYSIS<sup>a</sup>

Initial enzyme	Initial substrate	Final unbound ketoacid		Final unbound amino acid	
		Exp.	Calcd.	Exp.	Calcd.
$E_L = 2.37 \times 10^{-6}$	$G_m = 3.04 \times 10^{-5}$	$< 2 \times 10^{-6}$	$3.58 \times 10^{-6}$	$1.61 \times 10^{-5}$	$2.10 \times 10^{-5}$
$E_L = 2.37 \times 10^{-6}$	$As = 3.00 \times 10^{-5}$	$< 2 \times 10^{-6}$	$2.00 \times 10^{-6}$	$2.50 \times 10^{-5}$	$2.50 \times 10^{-5}$
$E_M = 2.44 \times 10^{-6}$	$Kg = 2.88 \times 10^{-5}$	$1.4 \times 10^{-5}$	$1.23 \times 10^{-5}$	$1.00 \times 10^{-5}$	$1.16 \times 10^{-5}$
$E_M = 3.25 \times 10^{-6}$	$Oa = 3.57 \times 10^{-5}$	$1.60 \times 10^{-5}$	$1.43 \times 10^{-5}$	$2.00 \times 10^{-5}$	$1.86 \times 10^{-5}$

<sup>a</sup> pH 8, 4°, all concentrations in M.

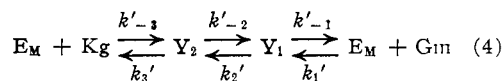

One of the relaxation times ( $\tau_1$ ) is much shorter than the other two so that the restoration of equilibrium for the step it characterizes can be assumed to be essentially independent of the other steps. Since the relaxation time of an uncoupled unimolecular reaction (e.g.,  $A \rightleftharpoons B$ ) should be independent of concentration,  $\tau_1$  must be associated with one of the bimolecular reactions in the mechanism. Furthermore since glutamate and aspartate are present in concentrations much higher than ketoglutarate and oxalacetate, the most logical assumption is that  $\tau_1$  and  $\tau_1'$  respectively characterize the steps

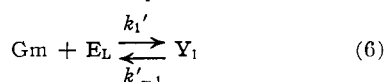
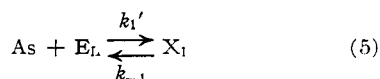

In this case the relaxation times can be shown readily to be<sup>6</sup>

$$1/\tau_1 = k_1(\bar{As} + \bar{E}_L) + k_{-1} \quad (7)$$

$$1/\tau_1' = k_1'(\bar{G}_m + \bar{E}_L) + k_{-1}' \quad (8)$$

where the bars designate equilibrium concentrations. If step 5 is assumed to be equilibrated much faster than the other steps (this is actually a direct consequence of the fact that  $\tau_1 \ll \tau_2$  and  $\tau_3$ )

$$-\delta X_1 = \frac{\delta X_2 + \delta E_M}{1 + [K_1(\bar{E}_L + \bar{As})]^{-1}}$$

Mechanism 3 can then be characterized by rate laws (9) and (10) in the neighborhood of equilibrium<sup>6,19,20</sup>

$$-d\delta E_M/dt = k_{-3}(\bar{E}_M + \bar{Oa})\delta E_M - k_3\delta X_2 = a_{11}\delta E_M + a_{12}\delta X_2 \quad (9)$$

$$-d\delta X_2/dt = \left[ \frac{k_2}{1 + [K_1(\bar{E}_L + \bar{As})]^{-1}} - k_{-3}(\bar{E}_M + \bar{Oa}) \right] \delta E_M + \left( k_{-2} + \frac{k_2}{1 + [K_1(\bar{E}_L + \bar{As})]^{-1}} + k_3 \right) \delta X_2 = a_{21}\delta E_M + a_{22}\delta X_2 \quad (10)$$

The coefficients  $a_{11}$ ,  $a_{12}$ ,  $a_{21}$  and  $a_{22}$  are defined by the above equations,  $\delta$  represents the difference between the actual and equilibrium concentration of the species under consideration, and  $K_1 = k_1/k_{-1}$ . The relaxation times can now be calculated (see ref. 6, 19 and 20 for details) by solving for the two

(19) G. G. Hammes and R. A. Alberty, *J. Am. Chem. Soc.*, **82**, 1564 (1960).

(20) R. A. Alberty and G. G. Hammes, *Z. Elektrochem.*, **64**, 124 (1960).

roots of the determinant

$$\begin{vmatrix} a_{11} - 1/\tau & a_{12} \\ a_{21} & a_{22} - 1/\tau \end{vmatrix} = 0$$

The results are

$$\frac{1}{\tau_{2,3}} = \frac{(a_{11} + a_{22}) \pm \sqrt{(a_{11} + a_{22})^2 - 4(a_{11}a_{22} - a_{12}a_{21})}}{2} \quad (11)$$

where the positive square root corresponds to  $\tau_3$  and the negative square root to  $\tau_2$ . In the limit where the equilibrium involving the bimolecular reaction is adjusted much more quickly than the other step, the relaxation times are

$$\frac{1}{\tau_3} = k_3 + k_{-3}(\bar{Oa} + \bar{E}_M) \quad (12)$$

$$\frac{1}{\tau_2} = \frac{k_2}{1 + [K_1(\bar{E}_L + \bar{As})]^{-1}} + \frac{k_{-2}}{1 + [K_3(\bar{E}_M + \bar{Oa})]^{-1}} \quad (13)$$

where  $K_3 = k_{-3}/k_3$ . In the present case equations 12 and 13 were found to be sufficient within 10 or 15% and were used as a first approximation. All of the final calculations were carried out using equation 11. Equations identical to 9-13 can be obtained for mechanism 4 except the equilibrium and rate constants are primed and the equilibrium concentrations of As and Oa are replaced by  $G_m$  and Kg, respectively.

The relaxation times contain 12 unknown rate constants (actually 10 rate constants plus one equilibrium constant, since  $\tau_1$  could not be measured due to its shortness and the small absolute effect). To determine these eleven constants are 13 measured relaxation times plus the mass conservation of substrate and enzyme for each experiment (16 equations). In addition the equilibrium constant for the over-all transamination is known to be about  $1/7$ .<sup>21</sup> An exact solution of such a system of equations is virtually hopeless; however a method of successive approximations was used, and it quickly became apparent that the order of magnitude of the various rate constants was quite rigidly fixed by the large number of equations which had to be satisfied.

A further refinement of the calculations was made by making use of the equilibrium spectra of the reaction mixtures. Since the substrate absorption is negligible above 300 m $\mu$ , the total absorbance,  $a$ , of a solution containing all of the reactants in mechanism 3 in the spectral region 300-600 m $\mu$  is

$$a = \epsilon_L(E_L) + \epsilon_M(E_M) + \epsilon_{X_1}(X_1) + \epsilon_{X_2}(X_2)$$

Here the epsilons are the extinction coefficients of the various species and a 1 cm. path length has been assumed. The analogous relationship for a reac-

(21) B. E. C. Banks, K. C. Oldham, E. H. Thain and C. A. Vernon, *Nature*, **183**, 1084 (1959).

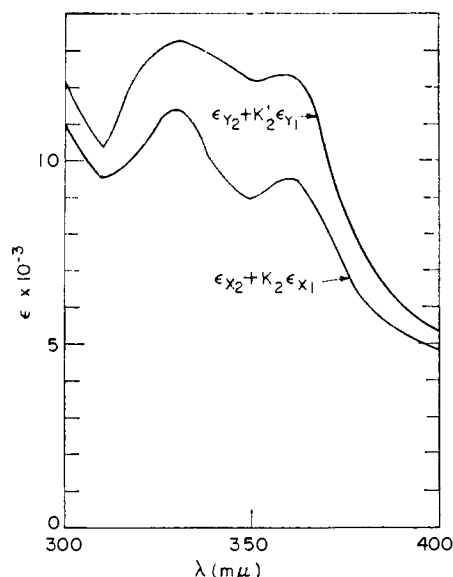

Fig. 3.—Spectra of transamination reaction intermediates. See text for explanation of symbols.

tion mixture involving the mechanism in equation 4 is obvious. Since  $\epsilon_L$  and  $\epsilon_M$  can be measured independently  $\epsilon_{X_1}(X_1) + \epsilon_{X_2}(X_2)$  can be determined for each reaction mixture. Furthermore this quantity divided by  $X_2$  should be a constant at any given wave length equal to  $\epsilon_{X_2} + K_2\epsilon_{X_1}$  where  $K_2 = k_{-2}/k_2$ . Thus the spectra provide another check on the consistency of the data and in addition give some information about the spectral properties of the intermediates.

The best fit of all the data is obtained by using the parameters

$$\begin{aligned} k_1/k_{-1} &= 1.8 \times 10^3 M^{-1} & k_1' &= 3.3 \times 10^7 M^{-1} \text{ sec.}^{-1} \\ & & k_{-1}' &= 2.8 \times 10^3 \text{ sec.}^{-1} \\ k_2 &= 80 \text{ sec.}^{-1} & k_2' &= 61 \text{ sec.}^{-1} \\ k_{-2} &= 26 \text{ sec.}^{-1} & k_{-2}' &= 30 \text{ sec.}^{-1} \\ k_3 &= 1.4 \times 10^2 \text{ sec.}^{-1} & k_3' &= 70 \text{ sec.}^{-1} \\ k_{-3} &= 7 \times 10^7 M^{-1} \text{ sec.}^{-1} & k_{-3}' &= 2.1 \times 10^7 M^{-1} \text{ sec.}^{-1} \end{aligned}$$

Although the measurement of the fastest relaxation time was too uncertain for calculation of  $k_1$  and  $k_{-1}$ , these lower bounds could be obtained

$$\begin{aligned} k_1 &> 10^7 M^{-1} \text{ sec.}^{-1} \\ k_{-1} &> 5 \times 10^3 \text{ sec.}^{-1} \end{aligned}$$

Using the above constants, all of the relaxation times (with one exception) can be calculated to  $\pm 10\%$ , which is well within the experimental error. The one exception is at the highest concentration used in the glutamate-enzyme system where the difference between the calculated and observed values is about 30%. A summary of the observed and calculated relaxation times is given in Tables I and II. Also included are the calculated concentrations of the various enzyme species present in each reaction mixture. The equilibrium constants of the various individual steps, the half reactions and the over-all reaction are easily calculable from the rate constants. Using the above rate constants, values of  $\epsilon_{X_2} + K_2\epsilon_{X_1}$  and  $\epsilon_{Y_2} + K'_2\epsilon_{Y_1}$  can be calculated to better than  $\pm 15\%$  in the concentration

range under consideration; these parameters are shown as a function of wave length in Fig. 3. At higher concentrations of substrate than those reported both the spectra and relaxation times deviate from their predicted values. This probably is due to several different effects. At high concentrations of glutamate ( $>5 \times 10^{-4}$ ) and aspartate ( $>1 \times 10^{-3} M$ ), combination of these two substrates with the aminic form of the enzyme probably occurs. Assuming a value of this binding constant of  $10^8 M^{-1}$  for glutamate and  $E_M$ , and  $10^2 M^{-1}$  for aspartate and  $E_M$ , all of the equilibrium spectral observations can be accounted for well within experimental error. An alternative possibility which is consistent with the experimental results is that the ketoglutarate formed begins to react with  $E_L$  at higher concentrations, thus lowering the effective enzyme concentration. Such an interaction is known to occur at lower pH's.<sup>8</sup> Whether or not the corresponding temperature jump data also are explained so simply is difficult to say since calculations cannot be made without knowing all of the rate constants involved. However, certainly the combined effects of coupling and superimposing relaxation times could account easily for the excessive shortening of the relaxation time observed at high concentrations. Finally a possibly explanation of the data at higher concentrations is that other intermediates become important and the simple mechanism proposed is not sufficient. A word of caution should be inserted here: although the rate constants given probably are precise to about  $\pm 25\%$  within the framework of the mechanism proposed, a mechanism involving more intermediates could certainly also be made consistent with the data. However, in such a complex case the assignment of the relaxation times to any of the various mechanistic steps is impossible. As is true with any kinetic investigation, only a minimal mechanism consistent with all known facts should be given. In the present situation, a very large number of kinetic and spectral observations are correlated within experimental error over the accessible concentration range.

Although the rather crude results of the stopped flow experiments cannot be used to postulate a mechanism, at least it can be seen if the data is consistent with the mechanism proposed on the basis of the temperature jump experiments. At the concentration of substrates employed the rate of equilibration of the enzyme-substrate reactions is fast compared to the rate of interconversion of intermediates; therefore the measured second order rate constants for the over-all half reaction are equal to an equilibrium constant (for enzyme-substrate formation) times a first order rate constant (for interconversion of intermediates) in terms of the proposed mechanism. The values of these over-all rate constants calculated from temperature jump data are presented in Table III together with the stopped flow results. In the cases where only lower bounds are obtained from the stopped flow data, the results from the two methods are consistent. Otherwise the rate constants obtained from the stopped flow are of the same order of magnitude, but slightly less than expected. Actually this is not too surprising because this simple

analysis assumed all of the reactions to be irreversible, while in point of fact this is a very poor approximation. An exact analysis of the full rate equations is not profitable, but qualitatively the effect of introducing the back reaction would be to make the apparent rate constant smaller, in agreement with the observed results. However, it should be emphasized that the only conclusion that can be stated with certitude is that the stopped flow results do not contradict the analysis of the temperature jump data.

Unfortunately the equilibrium dialysis experiments are also not conclusive. The agreement between the measured values of the final substrate concentrations and those predicted on the basis of the temperature jump experiments are given in Table IV; the agreement is certainly as good as one can expect considering the experimental errors and the fact that the two experiments were necessarily done at different temperatures. The desirability of carrying out the equilibrium dialyses at concentrations similar to those employed in the temperature jump experiments had two important consequences: (1) the concentration of substrates was such that often detection was barely within the limits of the analytical methods employed and (2) the per cent of substrate bound to the enzyme often was small. Thus in the cases where aspartate and oxalacetate were the initial substrates, the results really provided a good check of the over-all equilibrium of that particular half reaction, but did not provide a critical test of the proposed enzyme-substrate binding constants. For the other half reaction, on the other hand, a considerable fraction of the enzyme is present as intermediates according to the calculations. Again it can only be said that the two experiments are consistent within experimental error.

In principle, the results of these experiments should be able to predict the results of steady state kinetic studies. However, in the present case a complicating factor exists, namely, a monomer-dimer equilibrium is thought to exist for this enzyme.<sup>22</sup> In fact essentially all of the steady state experiments have been carried out with monomer enzyme, while in these experiments the enzyme is probably all dimer. Therefore it is not too surprising that the calculated Michaelis constants and maximum velocities differ considerably from those actually measured.<sup>11,12</sup> In fact, the values of both the maximum velocities and Michaelis constants are much greater for the monomer enzyme. This means the stabilities of the enzyme-substrate complexes are much greater with the dimer enzyme, but the interconversion of intermediates is slower. This trend is consistent with preliminary steady state experiments with the dimer enzyme<sup>22</sup> although a quantitative comparison is not yet possible.

The spectra in Fig. 3 both show two peaks, one at 330 m $\mu$  and another of lower intensity at 360 m $\mu$ . Since the difference in height between the two peaks is larger in the enzyme-4 carbon substrate system (aspartate-oxalacetate) where the equilibrium is more in favor of the second enzyme-substrate inter-

(22) P. Fasella, C. Turano, A. Giartosio, *Comm. to the First International Congress of Biophysics, Stockholm, 1961.*

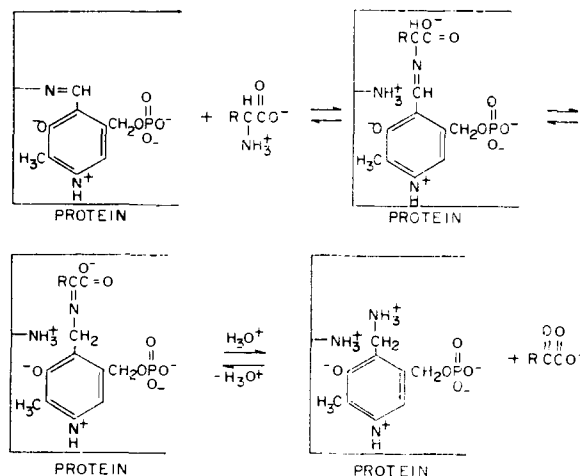

Fig. 4.—A schematic mechanism for enzymatic transamination. For aspartate-oxalacetate R is CH<sub>2</sub>COO<sup>-</sup>, while for glutamate-ketoglutarate it is CH<sub>2</sub>CH<sub>2</sub>COO<sup>-</sup>.

mediate, X<sub>2</sub>, the intermediates, X<sub>2</sub> and Y<sub>2</sub> probably can be identified with the peaks at 330 while the first enzyme-substrate intermediates (X<sub>1</sub> and Y<sub>1</sub>) probably absorb around 360. Absorption peaks around 360–370 m $\mu$  are characteristic of Schiff bases between pyridoxal phosphate and amino acids,<sup>23</sup> while absorption peaks around 310–330 m $\mu$  are found for pyridoxine derivatives with no conjugated double bond involving the carbon atom attached to position 4 of the ring. Thus the enzyme reaction in terms of the known parts of the active site can be written schematically for each half reaction as shown in Fig. 4.

Such a mechanism is consistent with that proposed for model reactions<sup>2</sup>; however to our knowledge this is the first direct kinetic evidence of such intermediates in the enzymatic transamination. As in the case of model reactions,<sup>2</sup> the rate limiting step at normal substrate concentrations is the conversion of one Schiff base into the other.

As usual the role of the protein moiety in the over-all mechanism is not clear. All of the bimolecular rate constants are of the order of 10<sup>7</sup> M<sup>-1</sup> sec.<sup>-1</sup>, while a typical value for model reactions (pyridoxal plus valine) is about 1 M<sup>-1</sup> sec.<sup>-1</sup>.<sup>24</sup> Therefore the enzyme catalyzes Schiff base formation by a factor of 10<sup>6</sup>. This probably is due to two effects: binding of the substrate in a critical configuration and concerted local acid-base catalysis. The value of 10<sup>7</sup> M<sup>-1</sup> sec.<sup>-1</sup> for the rate constant of enzyme-substrate formation is about 100 times smaller than that predicted for a diffusion controlled reaction.<sup>25,26</sup> Thus at least two more intermediates, the initial enzyme-substrate complexes, should be present in each half reaction. An interesting possibility is that a conformational change of the enzyme after the initial enzyme-substrate interaction is the rate controlling step in the Schiff base formation. The transformation of one Schiff base into another has a first-order rate constant about 10<sup>5</sup> times larger than typical model reactions.<sup>27</sup> Here

(23) Y. J. Matsuo, *J. Am. Chem. Soc.*, **79**, 2011 (1957).

(24) G. G. Hammes and P. Fasella, unpublished results.

(25) R. A. Alberty and G. G. Hammes, *J. Phys. Chem.*, **62**, 154 (1958).

(26) G. G. Hammes and R. A. Alberty, *ibid.*, **63**, 274 (1959).

again the possible rate controlling step might be a configurational change bringing the substrate into a critical position for reaction. For example, if the reaction is catalyzed by bringing one or more charged groups into a favorable position for polarizing the chemical bonds involved in the reaction, positioning would be critical since the potential energy of an ion-induced dipole interaction falls off as  $r^{-4}$ . Of course, if the interconversion of Schiff bases is acid-base catalyzed, conformation would also be very important. Although metal ions have been shown to be very effective in catalyzing model

(27) B. E. C. Banks, A. A. Diamantis and C. A. Vernon, *J. Chem. Soc.*, 4235 (1961).

reactions,<sup>2</sup> no significant amounts of metal ions have been found in purified glutamic-aspartic transaminase.<sup>28</sup> At the present time we are trying to measure protein conformational changes during the course of the reaction in order to ascertain whether or not the protein molecule is dynamically involved in the catalytic process.

The authors are indebted to Dr. M. Eigen and Dr. L. de Maeyer for helpful advice concerning construction of the temperature jump and to Mr. Gerald Becker for carrying out the stopped flow experiments.

(28) P. Fasella, G. G. Hammes and B. Vallee, *Biochim. et Biophys. Acta*, **65**, 142 (1962).

[CONTRIBUTION FROM THE NATIONAL INSTITUTE OF ARTHRITIS AND METABOLIC DISEASES, NATIONAL INSTITUTES OF HEALTH, BETHESDA, MARYLAND]

## Proton Magnetic Resonance of Amino Acids, Peptides and their Metal Complexes

BY NORMAN C. LI,<sup>1a</sup> ROBERT L. SCRUGGS<sup>1b</sup> AND EDWIN D. BECKER

RECEIVED JULY 27, 1962

The p.m.r. spectra for a series of twelve amino acids and peptides, in the absence and presence of cadmium and copper(II) ions, have been observed in 99.8% deuterium oxide, using benzene as an external reference. A quick and reliable n.m.r. method of determining volume magnetic susceptibilities, for the purpose of making corrections to chemical shift data, is described. Changes in the p.m.r. spectra on metal complexation have been interpreted to provide information on the assignment of p.m.r. frequencies and to give a better understanding of the nature of binding sites.

### Introduction

High resolution proton magnetic resonance spectroscopy has proved its ability to furnish information on the structure of a variety of substances in aqueous solution. Several papers<sup>2-5</sup> have appeared dealing with proton resonance studies of amino acids and dipeptides. Bovey and Tiers<sup>2</sup> have studied proton magnetic resonance (p.m.r.) spectra of amino acids and peptides in trifluoroacetic acid, and Jardetzky and Jardetzky<sup>3</sup> have studied the corresponding spectra of twenty-two amino acids in aqueous medium. With the single exception of a note by Li, *et al.*,<sup>5</sup> however, none of the p.m.r. spectra of amino acids and peptides have been studied from the viewpoint of metal complexes.

Li, *et al.*,<sup>5</sup> investigated the proton magnetic resonance of glycyglycinate, glycineamide and their zinc complexes, and came to the conclusion that high resolution p.m.r. spectroscopy represents an additional important approach to the study of complex formation. By combining the results of pH titration studies and the effects of metal ions on proton chemical shifts in glycyglycinate, it is possible to obtain a better understanding of the nature of the binding sites. Moreover, a combination of these two methods helps in the assignment of p.m.r. frequencies. These observations for glycyglycinate have now been extended to a survey of a

series of amino acids and peptides in aqueous solution, and the results are presented in this paper.

### Experimental

**P.m.r. measurements.**—P.m.r. spectra were obtained with a Varian Associates Model A-60 NMR spectrometer, together with a 30-cm. magnet system and superstabilizer. Spectra were scanned from low to high field at rates of 30 to 60 c.p.s./min. The frequency calibration of the A-60 spectrometer was checked with an audio oscillator and frequency counter. Solutions in 99.8% D<sub>2</sub>O were examined in spinning Wilmad coaxial cells with benzene in the annulus as an external reference compound. The accuracy in measuring the peak positions is estimated to be  $\pm 0.5$  c.p.s.; however, for broad or ill-defined peaks accuracy is, of course, lower. Data are reported in terms of the frequency independent unit  $\delta$

$$\delta = (\nu - \nu_{\text{benzene}})/60 \text{ p.p.m.} \quad (1)$$

with the positive sign given to peaks at higher field than benzene. The sample temperature was  $26 \pm 1^\circ$ .

**Magnetic Susceptibility Measurements.**—Since an external reference is used, bulk diamagnetic susceptibility corrections must be applied.<sup>6</sup> We have measured the susceptibilities by an n.m.r. method used in earlier work.<sup>5,7</sup> However, the details of this technique were not presented previously, nor has any evaluation of the accuracy of the method been given heretofore; hence the procedure will be described.

Immediately after the p.m.r. spectrum is taken, in the manner indicated above, we stop the spinning of the concentric cell and use the same assembly for making susceptibility measurements. The resonance from benzene in the annulus displays two maxima (see the n.m.r. trace in Fig. 1, in which water is placed in the inner cylinder) whose separation ( $n$  c.p.s.) is a linear function of the volume susceptibility of the liquid in the inner cell. This is because of the equation<sup>7</sup>

$$n = 4\pi\nu_0((k_1 - k_2)(a/r)^2 + (k_2 - k_3)(b/r)^2) \quad (2)$$

where  $\nu_0$  is the fixed radiofrequency, in this case 60 mc.,

(1) (a) Visiting Scientist from Duquesne University, Pittsburgh 19, Pennsylvania. (b) Research assistant on a National Science Foundation grant, No. G-21532, to Duquesne University.

(2) F. A. Bovey and G. V. D. Tiers, *J. Am. Chem. Soc.*, **81**, 2870 (1959).

(3) O. Jardetzky and C. D. Jardetzky, *J. Biol. Chem.*, **233**, 383 (1958).

(4) M. Takeda and O. Jardetzky, *J. Chem. Phys.*, **26**, 1346 (1957).

(5) N. C. Li, L. Johnson and J. N. Shoolery, *J. Phys. Chem.*, **65**, 1902 (1961).

(6) J. A. Popple, W. G. Schneider and H. J. Bernstein, "High Resolution Nuclear Magnetic Resonance," McGraw-Hill Book Company, New York, N. Y., 1959.

(7) C. A. Reilly, H. M. McConnell and R. C. Melsenheimer, *Phys. Rev.*, **98**, 261A (1955).